



City of Robbinsdale

POINT OF SALE UNIFORM
GUIDELINES



Revised June 7, 2011

EVALUATOR'S COPY

City of Robbinsdale
4100 Lakeview Avenue North
Robbinsdale, MN 55422

City of Robbinsdale

4100 Lakeview Avenue North • Robbinsdale, MN 55422 • 763.531.1269 / 763.531.1266 •
763.537.7344
www.Robbinsdalemn.com

Point Of Sale Uniform Guidelines TABLE OF CONTENTS

| | |
|---|--------------|
| FORWARD | i |
| INTENT OF THE POINT OF SALE ORDINANCE AND GUIDELINES | i |
| TOOLS OF THE TRADE | i |
| SETTING THE APPOINTMENT | ii |
| CONDUCT DURING THE EVALUATION | ii |
| CODE OF ETHICS | ii |
| COMPLETING THE DISCLOSURE FORM | iii |
| ADMINISTRATIVE DUTIES | iii |
| BASEMENT | 1 |
| 1. Basement Stairs | 1 |
| 2. Basement Floor | 1 |
| 3. Basement/Foundation Walls..... | 1 |
| 4. Evidence of Dampness or Staining | 1 |
| 5. Basement Sleeping Rooms | 2 |
| 6. First Floor/Floor System | 2 |
| 7. Columns & Beams | 2 |
| PLUMBING SYSTEM | 3-5 |
| 8. Floor Drain | 3 |
| 9. Waste & Vent Piping | 3 |
| 10. Water Piping | 3 |
| 11. Gas Piping | 4 |
| 12. Water Heater – Installation..... | 4 |
| 13. Water Heater - Venting & Combustion Air Supply | 5 |
| 14. Basement Plumbing Fixtures | 5 |
| 15. Copper Water Line on Street Side of Meter | 6 |
| ELECTRICAL SERVICE | 6-7 |
| 16. Electric Service Installation | 6 |
| 17. Smoke Detectors..... | 6 |
| 18. Separate 20 Amp Kitchen Circuit..... | 7 |
| 19. Basement Electrical Outlets & Fixtures | 7 |
| 20. Electrical Outlet for Laundry | 7 |
| HEATING SYSTEM | 7-9 |
| 21. Heating Plant Installation..... | 7 |
| 22. Heating Plant Viewed in Operation | 8 |
| 23. Heating Plant Combustion Venting | 9 |
| 24. Auxiliary Heating Units | 9 |
| KITCHEN | 9-11 |
| 25. Wall & Ceiling Components..... | 9 |
| 26. Walls & Ceilings – Evidence of Dampness or Staining | 9 |
| 27. Floor (Structural)..... | 10 |
| 28. Window Size & Operational Area | 10 |
| 29. Window & Door Condition | 10 |
| 30. Electric Outlets & Fixtures..... | 10 |
| 31. Plumbing Fixtures/Mechanical Ventilation | 10 |
| 32. Water Flow | 11 |
| 33. Gas Piping | 11 |
| DINING ROOM & LIVING ROOM | 11-12 |
| 34. Walls & Ceiling Components..... | 11 |
| 35. Walls & Ceilings - Evidence of Dampness or Staining | 11 |
| 36. Floor Areas & Ceiling Height | 12 |
| 37. Floor (Structural)..... | 12 |

| | |
|---|--------------|
| 38. Window Size & Operational Area | 12 |
| 39. Window & Door Condition | 12 |
| 40. Electrical Outlets & Fixtures..... | 12 |
| BATHROOMS | 12-14 |
| 41. Walls & Ceiling Components..... | 12 |
| 42. Walls & Ceilings - Evidence of Dampness or Staining | 13 |
| 43. Floor (Structural)..... | 13 |
| 44. Window Size/Operational Area/Mechanical Exhaust | 13 |
| 45. Window & Door Condition | 13 |
| 46. Electrical Outlets & Fixtures..... | 14 |
| 47. Plumbing Fixtures..... | 14 |
| 48. Water Flow | 14 |
| HALLWAYS & STAIRWELLS | 15-16 |
| 49. Walls & Ceiling Components..... | 15 |
| 50. Walls & Ceilings - Evidence of Dampness or Staining | 15 |
| 51. Floor (Structural)..... | 15 |
| 52. Window & Door Condition | 15 |
| 53. Electrical Outlets & Fixtures..... | 15 |
| 54. Stairs, Upper Floors..... | 15 |
| 55. Smoke Detectors..... | 16 |
| SLEEPING ROOMS | 16-17 |
| 56. Number of Sleeping Rooms..... | 16 |
| 57. Walls & Ceiling Components..... | 16 |
| 58. Walls & Ceiling - Evidence of Dampness or Staining | 16 |
| 59. Floor Area | 16 |
| 60. Floor (Structural)..... | 16 |
| 61. Window Size & Operational Area | 17 |
| 62. Window & Door Condition | 17 |
| 63. Electrical Outlets & Fixtures..... | 17 |
| PORCH – SUNROOM – OTHER | 18 |
| 64. Walls & Ceiling Components..... | 18 |
| 65. Walls & Ceiling – Evidence of Dampness or Staining | 18 |
| 66. Floor (Structural)..... | 18 |
| 67. Window & Door Condition | 18 |
| 68. Electrical Outlets & Fixtures..... | 18 |
| ATTIC SPACE | 19 |
| 69. Roof Board, Rafters & Insulation | 19 |
| 70. Evidence of Dampness or Staining | 19 |
| 71. Electrical Outlets & Fixtures..... | 19 |
| EXTERIOR | 19-22 |
| 72. Foundation | 19 |
| 73. Basement Windows | 19 |
| 74. Drainage..... | 19 |
| 75. Exterior Walls | 20 |
| 76. Doors (Frames/Storms/Screens | 20 |
| 77. Windows (Frames/Storms/Screens) | 20 |
| 78. Stoops | 20 |
| 79. Cornice & Trim | 20 |
| 80. Roof Covering & Flashing..... | 20 |
| 81. Chimney..... | 21 |
| 82. Electrical Outlets & Fixtures..... | 21 |
| 83. Two-Family Dwelling Egress | 22 |
| OPEN/UNHEATED TYPE PORCHES | 22 |
| 84. Floor (Structural)..... | 22 |
| 85. Walls (Structural) | 22 |
| 86. Roof (Structural) | 22 |
| 87. Doors/Screens/Windows | 22 |
| 88. Electrical Outlets & Fixtures..... | 22 |
| GARAGE/ACCESSORY BUILDING..... | 23-24 |
| 89. Roof Structure & Covering | 23 |
| 90. Wall Structure & Covering | 23 |
| 91. Garage Doors | 23 |
| 92. Electrical Outlets & Fixtures..... | 23 |

| | |
|---|--------------|
| MISC | 24 |
| 93. Egress/Ingress Obstruction | 24 |
| 94. Sanitation/Waste | 24 |
| 95. Vermin | 24 |
| 96. Guards | 24 |
| | |
| Appendices | 25-28 |
| Appendix 1 | 25 |
| Appendix 2 | 25 |
| Appendix 3 | 25 |
| Appendix 4 | 27 |
| Appendix 5 | 28 |
| Appendix 6 | 28 |

FORWARD

The purpose of this guide is to answer questions about the proper procedures to be followed by all Point Of Sale Evaluators licensed in the City of Robbinsdale. This guide covers information for evaluators from necessary equipment and how to fill out the evaluation report. If after reading this guide you still have questions, or anytime you're uncertain about a procedure, don't hesitate to call the City of Robbinsdale Community Development Division at **763-531-1266**.

The City of Robbinsdale Point Of Sale Disclosure Report and Guidelines are based upon a number of sources, including the City of Robbinsdale Property Maintenance Ordinance. All evaluators are required to follow the currently adopted Guidelines and other instructions specifically issued by the Point Of Sale Program Administrator.

INTENT OF THE POINT OF SALE ORDINANCE AND GUIDELINES

The Point Of Sale Ordinance is intended to protect the public welfare and improve the city's housing stock by identifying specific hazards upon time of sale for every one, two, three family structure, townhouse or condominium. It is expected that the evaluator will be a partner with the city in supporting full compliance with this and related ordinances. All home sellers are required to make repairs for all items marked as "**Repair/Replace**." This compliance is required for all evaluations. Evaluators are required to follow the guidelines in their entirety. Nothing herein shall exceed the requirements of the State Building Code

TOOLS OF THE TRADE

The evaluator is expected to have, at a minimum, the following tools and aids to assist with the actual evaluation:

1. A 4-5 foot stepladder (or one of sufficient size to allow the evaluator to easily access attic spaces).
2. 25' minimum measuring tape.
3. A flashlight.
4. A sharp instrument or tool such as an awl or ice pick.
5. An electrical outlet-testing device equipped with GFCI testing device.
6. Binoculars.
7. An electrical outlet tester with 2 flexible leads.
8. A means for testing the drafting of gas fired flues.
9. City of Robbinsdale Point of Sale Uniform Guidelines

SETTING THE APPOINTMENT

The evaluator shall discuss the fees for the initial inspection and any subsequent inspection(s) with the customer before making an appointment. The evaluator shall make a definite appointment time for the evaluation and then keep that appointment. Immediately upon arriving at the premises, the evaluator's identification shall be shown to the owner/agent/occupant. The evaluator is to prepare the home seller for this evaluation by informing them that:

- a. Access to all spaces, including the attic, the garage, and all mechanical systems is required. All obstructions must be removed prior to the evaluation. If the owner/occupant refuses to make the attic accessible, the evaluator shall indicate this fact on the report.
- b. All auxiliary heating systems should be up and running in the specified season (October 1 to May 15). All utilities (gas, water, electric) must be on.
- c. Point Of Sale Evaluation does not replace a Housing / Code correction order. Refer the home seller to the City of Robbinsdale Housing Inspector 763-531-1261.
- d. The evaluator shall inform the seller that the Point Of Sale Disclosure Report will not be valid without their signature and a statement regarding flood damage, sewer back-up, water seepage, any abandoned, unused, or uncapped wells, any discharge of storm water, groundwater, roof runoff, yard drainage, foundation drains, or sump pumps into the sanitary sewer.

CONDUCT DURING THE EVALUATION

The owner/agent/occupant may be invited to accompany the evaluator on the evaluation tour. Make it clear to the owner/agent/occupant the Point Of Sale evaluation is based upon a visual inspection; the evaluator is not expected to remove cover plates and/or access doors requiring the use of tools, and does not require the owner/agent/occupant to do so either. Politely suggest that the owner/agent/occupant ask all the questions they wish and request that they point out features known to them that may assist you in determining the age and/or condition of the dwelling's mechanical and electrical systems. This is not a mandatory requirement, but it may serve to furnish the evaluator with considerable information concerning the age and/or condition of the structural, mechanical, and electrical components of the dwelling.

Tell the owner that after the evaluation you will be glad to discuss the report. You should go over the items marked "**Repair/Replace**" and inform the owner that these items must be corrected and inspected by a City inspector. All required informational pages and/or forms must be provided to the customer by the evaluator. The owner shall be informed that city permits may be required for items marked as "**Repair/Replace**" and all questions in that regard should be addressed to the City of Robbinsdale Inspections Division 763-531-1265.

CODE OF ETHICS

1. The evaluator will not discriminate on any basis in providing services and establishing fees.
2. The evaluator, while acting as such, will not operate under the use of alcohol, drugs or narcotics, even if prescribed by a physician, which may impair his/her judgment or performance as an evaluator.
3. The evaluator will not knowingly re-evaluate any premises for which a previous evaluation remains in force. However, if since a prior inspection, conditions have changed or repairs have been made of items noted, or were not accessible, or when instructed to do so by the administrative authority, in such inspection, the evaluator who made the prior inspection, may re-evaluate the premises.
4. The evaluator will be responsible at all times to execute his/her duties with due care and in good faith, in compliance with the laws and regulation of the City of Robbinsdale, in compliance with the City of Robbinsdale Evaluator Guidelines and with the evaluator's Code of Ethics. Failure of the evaluator to comply with the law and the City of Robbinsdale direction through the Evaluator Guidelines shall constitute an infraction of the Code of Ethics.
5. The evaluator, while acting as such, will not engage in conduct that in any way is in violation of any law or ordinance, or is in contravention of good order and decorum.
6. The evaluator will respond to all complaints received regarding his/her evaluation in a timely manner.

7. The evaluator will not knowingly submit or prepare for a homeowner, an evaluation that contains false or misleading statements. All evaluations made shall be completed upon the forms supplied by the City of Robbinsdale, and shall be submitted to the duly appointed recipient and custodian of such completed forms.
8. Failure of the evaluator to respond to the requests, written or oral, of the City of Robbinsdale shall constitute an infraction of the Code of Ethics.
9. The evaluator will not evaluate properties in which he/she or his/her immediate family has an interest. For purposes of this provision, immediate family shall mean parents, children, spouse and siblings. Immediate family shall further mean those persons living together in a dwelling comprising a single household unit.
10. The evaluator will not engage in business practices with any person in the real estate field when such practice could be construed to be collusion.
11. The evaluator, while acting as such, will not endorse specific materials or firms. He/she will not appraise the value, or estimate the costs of repairs or services for properties he/she is evaluating. The evaluator will not make any repairs or additions to a property he/she has evaluated, during the time period the evaluation he/she conducted is valid.
12. The evaluator, while acting as such, will not solicit the property for sale, nor suggest services of specific agencies or agents.

COMPLETING THE DISCLOSURE FORM

The Point Of Sale of Housing Disclosure Report form must be filled out completely. All entries must be made in ink, or typed, or computer-generated. The City of Robbinsdale's program requires that all items marked "**Repair/Replace**" must be corrected.

If any numbered item for evaluation cannot be viewed or be evaluated, "**Comment**" with an explanation for no evaluation. If no reason is given, the report is incomplete and will be returned to the evaluator to finish, and will be **null and void** if not re-submitted within the allowed filing period as required by ordinance.

If a component warrants a "**Below City Requirement**" rating, a "**Comment**" is required.

ADMINISTRATIVE DUTIES

This is not a complete list. See Section 435 for the full list of duties.

1. Any forms that evaluators file, as amendments, must be submitted according to the same timelines as an initial Point Of Sale of Housing Disclosure Report, per Section 435 City of Robbinsdale Point Of Sale Ordinance. All reports must be filed within 10 days (including weekends and holidays) of the date of the report, or will the report will be **null and void**.
2. All evaluator-produced or computer generated forms must be pre-approved by the Robbinsdale's Point Of Sale of Housing program prior to their use.
3. The evaluator shall completely and clearly fill out the Point Of Sale Housing Disclosure Report form. Write the address and date lengthwise in the area provided and staple the report together, if the pages are loose. Fill out the form neatly and in blue or black ink.
4. Each evaluator is required to have a **current** certificate of competency as issued by the City of Minneapolis, City of Bloomington or the City of St. Paul.

BASEMENT

1. Basement Stairs

- A. Determine if the stairway(s) leading to the basement are safe to use and capable of supporting the load that normal use would cause to be placed upon them. If the stairway(s) are not capable of supporting such loads mark as **“Repair/Replace.”**
- B. Check stringers for any signs of decay, sagging, or deterioration. If any of these conditions exist this item will be marked as **“Below City Requirements.”**
- C. Determine if the stairway(s) rise, run and width are proper (Min. tread 9”, max. rise 8”, min. width 36”). The greatest riser height within any flight of stairs shall not exceed the smallest by more than 3/8 inch). If the stairway(s) does not meet these minimums, mark as **“Below City Requirements.”**
- D. Determine if the headroom is less than 6’-8.” If so, it shall be marked as **“Below City Requirements.”**
- E. Determine if the handrail(s) are properly installed and securely attached at the proper height (30” - 38” high as measured from the nose of the tread). The handrail(s) shall be full length, with the ends returned. Handrails must be separated by 1½ inches from any wall. If any of these requirements are not met mark as **“Below City Requirements.”**
- F. If the stairway has an open side it must have a guardrail that is a minimum of 34” in height with intermediate rails that are spaced so that a 4 3/8” sphere cannot pass through the openings. If either of these criteria is not met it shall be marked as **“Below City Requirements.”**
- G. Every stairway having 4 or more risers shall have at least one handrail. Stairways missing required handrails shall be marked as **“Below City Requirements.”**

2. Basement Floor

- A. Check the floor/slab and list any evidence of heaving, buckling, large cracks or other conditions that indicate problems or inadequate soil bearing. If such evidence exists mark as **“Comment”** with an explanation.
- B. If there is dirt floor or if the concrete floor does not cover all useable floor areas of the basement, mark as **“Below City Requirements.”**
- C. If the floor has any holes or raised edges exceeding ½ inch that may be a potential trip hazard mark it as **“Below City Requirements.”**

3. Basement/Foundation Walls and Area Below Slab Floors

- A. Check the basement walls and ceilings for leaning, cracking, buckling, or bulging conditions that may indicate a potential structural failure. If in the evaluator’s opinion there is a potential for structural failure of the basement wall or ceiling, mark as **“Repair/Replace.”**
- B. Check walls for any missing, cracked or deteriorated blocks, bricks, stones or mortar, note any spalling of walls and/or blistering paint. If any of these conditions exist this item will be marked as **“Below City Requirements.”**
- C. Where crawl spaces exist, the evaluator need not crawl into the space, but will use any holes or openings into these spaces to evaluate the condition of all visible foundation walls and floor system. If the evaluator is unable to evaluate the crawl space mark this as a **“Comment”** with an explanation.
- D. Evaluate the foundation wall(s). If the foundation walls are concealed or covered by permanent building materials, and there are no other indications of deterioration, the evaluator must then mark this as a **“Comment”** and indicate the extent of concealing. If the masonry walls are covered by installed building or remodeling materials evaluate and grade the installation as you would any other wall. Mark **“Below City Requirements”** any wall or wall covering not found to be in a professional state of repair.

4. Evidence of Dampness or Staining

- A. Check for evidence of past or present dampness or staining (dampness, stains, efflorescence or decay) and mark either **“Yes”** or **“No”** on the form. If **“Yes”** is marked, **elaborate in the Comments column.** Pay particular attention to the bottom of any wood (stair stringers, columns, shelving, and

paneling) in contact with the slab/floor when checking for this evidence.

- B. If area(s) are concealed or covered, state this in the **"Comments"** column and identify the obstruction and indicate the extent of the concealment. Evaluate and grade the installation of what is visible.
- C. If there is evidence of clear water (rain, snowmelt, ground water) entering into the house and flowing to, or being directed towards the sanitary sewer system via a floor drain, any plumbed fixture, vent or drain; or an illegally discharging sump pump, mark **"Yes"** and include a brief description and or photo in the **"Comments"** column as an Inflow / Infiltration (I / I) concern.

5. Basement Sleeping Rooms

**** NOTE:** if there is a sleeping room located in the basement, the evaluator must note "Yes" and their notation shall say "Refer to Items 56 - 63" and mark any additional comments in the **"Comments"** column.

- A. Item 5 applies only to sleeping rooms located in basements. The evaluator shall determine if all sleeping rooms meet the necessary requirements for a bedroom, but comment in section 56-63.
- B. A recreation room is deemed by these guidelines a non-habitable room, but the evaluator shall determine if the wiring, plumbing and other components are properly and safely installed and note any deficiencies in the **"Comments"** column.

NOTE: If an evaluator believes that a room is being used illegally for sleeping purposes, the evaluator should not count it as a legal sleeping room and should mark it in the comments column and evaluate it as such.

6. First Floor/Floor System

- A. Check joists and other wood-framing members where they enter masonry walls for dry rot or insect damage. The evaluator shall utilize the awl or ice pick to determine if dry rot is present and indicate the findings in the proper column after Item 6. If any of these items exist mark as **"Below City Requirements."**
- B. Check the joist system for excessive notching or over-spanning or boring and any other evidence of structural failure. If any of these items exist indicate the findings in the comments column and mark as **"Below City Requirements."** If there are signs of structural failure or there is a potential for structural failure, mark this item as **"Repair/Replace."**

Notching & Boring Standards: Notches in solid lumber joists, rafters and beams shall not exceed one-sixth of the depth of the member, shall not be longer than one-third of the depth of the member and shall not be located in the middle one-third of the span. Notches at the ends of the member shall not exceed one-fourth the depth of the member. The tension side of members 4 inches or greater in nominal thickness shall not be notched except at the ends of the members. The diameter of holes bored or cut into members shall not exceed one-third the depth of the member. Holes shall not be closer than 2 inches to the top or bottom of the member, or to any other hole located in the member. Where the member is also notched, the hole shall not be closer than 2 inches to the notch. (See Diagram in Appendix 4)

- C. Check the sub-floor for dry rot or water seepage that could indicate leaks in the plumbing system. If decay exists on the sub-floor it must be marked as a **"Below City Requirements."** If there is evidence of water seepage a **"Comment"** must be present in the Comment column of the report.
- D. Where crawl spaces exist, the evaluator need not crawl into this space, but will use any holes or openings into the crawl space to inspect the visible beams, floor joists, and sub-floor system for any deterioration. Check to see the proper clearance to soil exist (18" minimum to joists and 12" to beams, unless treated). If they do not, mark this item as **"Below City Requirements."**
- E. Whenever the evaluator finds that the support system (columns, beams, etc.) is covered or concealed by permanent building materials, and it may not be evaluated mark it as **"Comment," and indicate the extent of concealing.**

7. Columns & Beams

- A. Check all beams and columns for rot, decay and insect damage. Also check for improper holes or notches, sagging, lack of support or improper supports. Some notching and boring is acceptable. If any of these conditions exist, this item will be marked as **"Suggested Correction"**. If there are signs of structural failure, or a potential for structural failure, mark this item as **"Repair/Replace."**

- B. The minimum standards do not specifically require that the columns be supported on a surface above the basement floor. However, the evaluator shall determine if the column remains in sound and good structural condition by utilizing the awl or ice pick at floor level. If the column is not in sound condition mark as **“Below City Requirements.”**
- C. The use of adjustable posts or other temporary types of supports may indicate a structural problem, and the condition of such temporary supports should be carefully examined and noted as a **“Comment”** in the comments column. Any adjustable post not made permanent by removing the pin and spot-welding or peening the thread and properly anchoring the post will be marked as **“Below City Requirements.”**
- D. The evaluator shall check for evidence that the columns have settled, if found, this shall be marked as **“Below City Requirements.”**
- E. If area(s) are concealed or covered by permanent building materials, **“Comment,”** and indicate the extent of concealment and condition of what is visible or uncovered.

PLUMBING SYSTEM

8. Floor Drain

- A. If no floor drain exists, the evaluator shall note this by printing **“NOT APPLICABLE”** in the box provided and explain in the **“Comments”** column that a floor drain was not found.
- B. Determine if the floor drain has a water seal trap, a tight fitting secure cleanout plug, a secure grate, is free of debris, and appears to be functioning. If the grate is not secure or there is debris, mark this item as **“Below City Requirements.”** If the evaluator determines that the drain is not water sealed or the clean out plug is missing and/or not secure or does not appear to be functioning, mark as **“Repair/Replace.”** When this is found, the evaluator’s comments must read **“replace missing clean out plug and make floor drain operational with clean out plug in place.”**

9. Waste & Vent Piping (Use this section as guideline for evaluating all floors)

- A. Check the visible waste lines for signs of leakage or seepage, if found, mark as **“Repair/Replace.”**
- B. Check for repairs made with improper materials (tape, tar, rags, putty, etc.), if found mark as **“Below City Requirements.”** If the potential for sewer gas exists mark as **“Repair/Replace.”**
- C. If the use of saddle type connections is present indicate this as being **“Below City Requirements.”** (See Appendix 1; State Plumbing Code Section 4715.0800 subp5. for some that are allowed by the State)
- D. Determine if all visible waste and vent pipes are of approved materials, if they are not, and if black or white plastic (ABS & PVC) waste pipes are improperly connected and/or mixed together, mark these conditions as **“Below City Requirements.”**
- E. Determine if all visible waste lines are properly vented, if not mark item as **“Suggested Correction.”**
- F. Check to see that all waste or vent openings are properly plugged or secured. If these openings are not plugged or secured, mark as **“Repair/Replace.”**
- G. The evaluator shall determine if a clean out for the building sewer is provided either at the wall where the waste system leaves the building or at the base of the main stack. If no such clean out is provided, indicate the condition as being **“Below City Requirements.”**

10. Water Piping

- A. Determine if all water piping has been properly installed and supported in accordance with the 2008 Minnesota State Plumbing Code. Approved materials include galvanized steel, copper tubing and plastic pipe. Rubber hose is not approved for use as interior water supply piping. Plastic water piping (CPVC and Poly Butylene) must meet all requirements for installation and materials. If unable to determine the type of materials used, mark as **“Comment”** and explain this in the Comment column of the report. Unapproved materials shall be marked **“Below City Requirements.”**
- B. Determine if the water piping is of size and condition so as to furnish at least two fixtures with an uninterrupted supply of water simultaneously. No more than three (3) fixtures can be supplied by a ½" pipe. If these conditions do not exist mark this item as **“Below City Requirements.”**

- C. Check the water piping for crimping that may seriously restrict water flow and record these conditions as **“Below City Requirements.”**
- D. Note the presence of any saddle type connections or unapproved repair clamps on the water lines as being **“Below City Requirements.”**
- E. If the evaluator finds that any hot or cold water piping has been removed from a kitchen sink, water closet, lavatory or bathtub or shower, the evaluator shall mark **“Repair/Replace.”**
- F. Note if any water piping enters into unheated areas of the building where it would be subject to freezing during cold weather. The evaluator will mark this as **“Comment”** and explain in the Comment column of the report.
- G. Check exterior fixtures. Note the absence of any back-flow prevention device on the exterior water fixtures as **“Below City Requirements.”**
- H. All floors, interior: Any water outlet below the spill ring and/or capable of attaching a hose on the water outlet requires a back-flow prevention device. If no such device is present, mark this item as **“Below City Requirements.”**

11. Gas Piping

- A. See the attached copy of appliance fuel connectors Section 2214 Appendix B of the 2006 Uniform Mechanical Code. If any of these connectors are not in compliance with Appendix 6, mark as **“Below City Requirements.”**
- B. Determine if the gas piping has been properly installed and supported using approved materials. If unapproved materials are used; if the gas line is kinked or deteriorated to the extent that it may cause a gas leak, mark as **“Repair/Replace.”**
- C. Determine if approved (AGA) flexible gas appliance connectors were used. If an unapproved connector was used, mark this as **“Suggested Correction.” See Appendix 6 for a detailed list of gas connectors’ specifications.**
- D. All gas appliances, including gas dryers, must have a shutoff valve and be located within 6 feet of the appliance. If the shutoff valve is not located within 6 feet of the appliance and in the same room or if a shutoff valve is not present mark as **“Below City Requirements.”** Evaluators must also attempt to slightly move all valves. If valves are broken or seized to the point that they will not operate, mark as **“Repair/Replace.”**
- E. Check to see that the required drip leg, drip tee or sediment trap is provided on gas piping when dropping down to all thermostatically controlled appliances. If none is provided, mark as **“Below City Requirements.”**
- F. Determine if gas piping remaining after the disconnection of an appliance has been properly plugged or capped. If the piping is not properly plugged and capped, mark as **“Repair/Replace.”** Comments must read, **“If owner installs a gas appliance, a plumbing permit is required.”**
- G. The evaluator shall determine if the dryer has a proper vent. Dryer vents shall be of smooth or flexible metal material. The flexible vent shall not exceed 8 feet in length. The total length of the vent is not to exceed 25 feet. Five feet shall be deducted for each 90-degree elbow. If the vent is not an approved type, mark as **“Below City Requirements”** (Current State Code).
- H. If there are gas lines that go through the foundation wall to the exterior it shall be noted by **“Comment”**

12. Water Heater - Installation

- A. Check the visible condition of the water heater. If there is any evidence of rusting, or leakage from the drain cock or temperature and pressure relief valve, mark as **“Below City Requirements.”** If there is any evidence of scorching, or any missing or broken control valves, or leaking from the tank, mark as **“Repair/Replace.”** Excessive mineral deposits on the water heater should have **“Comment.”**
- B. Determine if the water heater is located over a noncombustible floor and is set firmly on the slab or floor. If the water heater is improperly installed, mark as **“Below City Requirements”** and comment in the Comments column, **“water heater is installed on combustible surface.”** If the manufacturer’s guidelines are present and they prohibit this installation, mark as **“Repair/Replace.”**

- C. Determine if the water heater is provided with a temperature and pressure relief valve. If there is no temperature and pressure relief valve, mark as **“Repair/Replace.”**
- D. Check to see that the relief valve is properly attached to the water heater within the stated distance, on the tag, or installed within six (6) inches of the top of the water heater. If the relief valve is improperly located or installed, mark as **“Repair/Replace.”**
- E. Check to see that there is a drain (discharge) pipe attached to the relief valve. The discharge line must terminate within 18 inches of the floor, unthreaded and uncapped on the bottom end, and the same size as the relief valve outlet for the full length. If the discharge pipe does not meet these standards, mark as **“Repair/Replace.”**
- F. If the water heater is electric or gas and is not on, mark as **“Repair/Replace - Incomplete Report.”**

13. Water Heater - Venting & Combustion Air Supply

- A. When possible the evaluator shall observe the venting system in operation. If the water, gas and/or pilot are turned off, the owner or agent must turn on all necessary elements to the unit for evaluation. If the venting system is not viewed in operation, the evaluator shall mark **“REPAIR/REPLACE - INCOMPLETE REPORT.”** The evaluator shall note in the Comments column that either a **“Certification”** will be required by an approved Licensed Contractor or a re-inspection by the same evaluator will be necessary before a **Certificate of Approval** will be issued.
- B. Determine if a gas fired water heater is provided with a draft hood (diverter), and the flue material is approved for use with gas fired appliances. Check the flue system for rust holes, negative pitch, open joints, lack of proper support and improper sealing to the chimney. If any of these conditions exist mark as **“Repair/Replace.”** If there are not three screws at each flue connection, mark as **“Below City Requirements.”**
- C. Check for back spillage at the draft hood. The spillage can be tested by turning on a hot water faucet and allowing the water to run until the water heater turns on, then a lit match or smoke should be placed by the draft hood to test if it is properly drafting. If back spillage is evident this shall be marked as **“Repair/Replace.”** Add in the **“Comments”** **“a licensed contractor is required to verify the appliance is no longer back drafting.”**
- D. Determine if the flue piping has the proper clearances from combustible materials and is properly supported. If a loose heat shield is present it should be noted in the Comment column; if the proper clearance is not provided mark this item as **“Repair/Replace.”**
- E. **“Comment”** if the water heater is electric. No venting is required for electric water heaters.
- F. If the water heater flue enters another appliance flue line, it must enter that line at a forty-five (45) degree angle and be consistent with the flow of the flue line entered. If these conditions are not met mark this item as **“Below City Requirements.”**
- G. If flues from separate gas appliances enter a chimney on opposite sides and are not offset in height mark as **“Repair / Replace.”**

14. Basement Plumbing Fixtures

- A. Note any plumbing fixtures that are broken, cracked, leaking or are not protected with a water seal trap, or in such condition as to give rise to unsanitary conditions. If any of these conditions exist, mark as **“Repair/Replace.”** Repairs must be made in a professional and long lasting nature. Temporary caulk, glue or similar materials are not acceptable repairs.
- B. Determine if the basement plumbing fixtures are improper installations or have no visible signs of any waste and/or venting, if so mark as **“Suggested Correction.”**
- C. Note the presence of any abandoned plumbing fixtures or openings in the basement or cellar and determine if these openings are properly sealed. If the openings are not sealed, mark as **“Repair/Replace.”**
- D. All plumbing waste lines must be vented to the requirements of the current Minnesota State Plumbing Code. If determined that it is not properly plumbed, mark as **“Suggested Correction.”**
- E. A sump pump must discharge directly to the outside. Mark as **“Repair/Replace”** if it discharges to the sewer line.

15. Copper Water Line on Street Side of Meter

- A. The evaluator shall determine if the water piping on the street side of the meter is or is not copper and indicate an appropriate “**Yes**” or “**No**” answer on the form. (If in doubt, scrape the water line to see if it is copper or Tube alloy).
- B. If a well is present make “**Comment.**”

ELECTRICAL SERVICE

16. Electric Service Installation

- A. When possible the evaluator shall observe the electrical system in operation. If the system is turned off, the owner or agent must turn it on. If electricity is not supplied to the building the evaluator shall mark “**Repair/Replace - Incomplete Report.**” Note in the Comments column that either a “**Certification**” will be required by a Minnesota Licensed Contractor or a re-inspection by the same evaluator will be necessary before a **Certificate of Approval** will be issued.
- B. Whenever the evaluator determines that the electrical service based on a visual inspection has been altered or tampered with so that a reasonable evaluation cannot be performed, the evaluator may mark “**Repair/Replace.**” The evaluator must then mark “**Certification Required**” in the comments column.
- C. If the evaluator observes two major 240-volt appliance circuits on a 60-amp service, mark “**Below City Requirements.**”
- D. The evaluator shall determine whether the service installation is proper. Note conditions such as rust, damage, clearances, obstructions, missing parts, etc. If such conditions exist, mark as “**Below City Requirements.**” If electrical shock is possible by direct contact, mark as “**Repair/Replace.**”
- E. The evaluator shall note evidence of over-fusing or tampering. Evidence of over-fusing or tampering shall be marked as “**Repair/Replace.**”
- F. The evaluator shall determine the ampere rating of the service and indicate it on the report.
- G. One electrical meter for two dwelling units must be marked as a “**Comment**” with an explanation in the Comments column.
- H. The electric service shall be grounded to the city side (also known as the street side) of the water meter either directly or by a ground jumper or by a ground rod. If it is missing or not properly grounded, it shall be marked as “**Repair/Replace.**”

17. Smoke Detectors

Installation shall be as required by State Statute 229F.362 POLICY # INS 199-14.

- A. All smoke detectors when located on the ceiling shall not be less than 4 inches from a wall or on a wall with the top of the detector not less than 4 inches, or more than 12 inches, below the ceiling. If a smoke detector is improperly located mark as “**Repair/Replace.**”
- B. If the smoke detector is connected to an alarm system, do not test it. Mark as “**Comment**” with the statement “**testing was not done due to the alarm system.**”
- C. Smoke detectors shall be required on every story of the dwelling unit, including basements. One smoke detector on each level of the dwelling, including the basement. Lack of a smoke detector must be marked as “**Repair/Replace.**” Smoke detectors are not required inside each bedroom, but shall be in the hallways or areas giving access to each separate sleeping area.
- D. In dwelling units with split-levels and without an intervening door between the adjacent levels, a smoke detector installed on the upper level shall suffice for the adjacent lower level provided that the lower level is less than one full story below the upper level. If smoke detectors do not meet these standards, mark as “**Repair/Replace**” and elaborate in the comment column where violations occur.
- E. All smoke detectors must be operational. The evaluator shall test each smoke detector in the dwelling. If any smoke detector is not operational, mark as “**Repair/Replace.**” If batteries for the smoke detector are missing or dead, mark “**Suggested Correction.**” The smoke detector cover must be attached. If the detector is operational, but the cover is missing, mark “**Below City Requirements.**”

18. Separate 20 Amp Kitchen Circuit

- A. The evaluator shall indicate, “**Yes**” or “**No**” if the electrical service box has a 20-amp kitchen circuit indexed at the service panel.

19. Basement Electrical Outlets & Fixtures

For all areas, unless specified elsewhere.

- A. Determine if the minimum number of electrical outlets and fixtures provided in the basement/cellar area comply with Section 425.17 Subd.4.. The following regarding electrical outlets in existing dwellings: Every habitable space in a dwelling shall contain at least two separate and remote receptacle outlets. Every public hall, interior stairway, water closet compartment, bathroom, laundry room and furnace room shall have at least one electric lighting fixture. If these items do not exist, mark as “**Below City Requirements.**”
- B. Determine if all wiring, outlets and fixtures present in this area, whether required or not, have been properly installed, maintained and energized in a manner which complies with the National Electrical Code required at the time of installation. If not, mark as “**Below City Requirements.**” If there is a metal pull chain on the fixtures, mark as “**Below City Requirements.**”
- C. Any extension cords used in lieu of permanent wiring or extension cords located in inappropriate areas (under floor covering, through walls, etc.) shall be marked as “**Repair/Replace.**”
- D. Check for broken receptacles, switches, missing cover plates, missing knock outs and broken parts where electrical shock is possible by direct contact and mark as “**Repair/Replace**” if any of these conditions are found.
- E. Randomly check at least half of all outlets with an electrical outlet-testing device, to determine that any three prong, grounding type outlets, in use, are properly grounded. If not properly grounded mark as “**Below City Requirements**” or “**Suggested Correction.**”
- F. Replacement of any bathroom receptacles must be in accordance with the State Electrical Code. Remodeling or upgrading of the electrical service may require that outlets be grounded and/or G.F.C.I. outlets. If this condition is not met, mark as “**Repair/Replace.**”
- G. Note: The City of Robbinsdale does not require that outlets by water be grounded or have a ground fault circuit interrupter outlet used because it is not required by the minimum standards of the National Electrical Code for existing dwellings.

20. Electrical Outlet for Laundry

Evaluator shall indicate “**Yes**” or “**No**” regarding the presence of an electrical outlet and whether it is indexed where there are laundry facilities.

HEATING SYSTEM

21. Heating Plant Installation

- A. Determine the type of main heating system and the type of fuel used, and mark this information in the space provided for the principle residence and all accessory structures.
- B. If more than one main and one auxiliary heating system are installed, note the type of systems and fuels used, in the Comments column of the report.
- C. Inspect the visible exterior and interior areas of the heating plant. If the cover panels can be removed without the use of tools, check the interior for signs of leakage, cracks, excessive rust, scorched areas and for missing or deteriorated seals. If found, the following items will be marked as “**Repair/Replace**” 1) Signs of leakage. 2) Cracks in the combustion chamber. 3) Cracked and/or damaged casing.
- D. If found the following items will be marked “**Below City Requirements**” 1) Rusted areas 2) Scorched areas 3) Uneven discoloration of heat exchanger.
- E. Check for proper clearance to combustibles. The clearance rating may be noted on the nameplate of the appliance. If there is improper clearance to combustibles mark as “**Repair/Replace.**” If clearance to combustibles rating is not found or determined this should be stated in the **Comments** column of the report.

- F. Check the safety controls. The evaluator need not test the safety controls to determine if they operate, but if a gas shut-off valve is missing or visibly defective the evaluator will mark this item as **“Repair/Replace.”** If the thermostat or plug valves are visibly defective or missing mark this as **“Below City Requirements.”**
- G. The evaluator will check for and record the presence of the following conditions:

1. Gas Fired Heating Plants:

- a. Look for excessive condensation within the dwelling, this could result in or be the result of a rusted or cracked heat exchanger or a rusted or blocked vent connector or a blocked chimney. A **“Comment”** should be made if this condition is found.

2. Warm Air Heat:

- a. Determine if ductwork is in good condition, properly secured and tight at all connections. If these conditions are not met this item will be marked as **“Below City Requirements.”**

3. Hot Water Systems:

- a. Check the water supply piping leading to the boiler for a backflow preventer or a check valve; if none is found mark this item as **“Repair/Replace.”**
- b. Check the boiler and expansion tank to determine if a drain valve has been provided to allow proper draining of the boiler and expansion tank. If no such valves are found mark this item as **“Below City Requirements.”** If the expansion tank is open to the atmosphere, no drain valve is required.
- c. Check the boiler and expansion tank to determine if a shutoff valve is provided. If no such valves are found mark this item as **“Below City Requirements.”** The shutoff valve for the boiler should be located on the water supply line. The shutoff valve for the expansion tank should be located in the line between the boiler and the expansion tank. If the expansion tank is open to the atmosphere, no shutoff valve is required.
- d. If no expansion tank is present or visible this item will be marked as **“Below Minimum Requirement.”**
- e. Determine if the boiler is provided with a combined temperature and pressure relief valve. If no relief valve is provided mark this item as **“Repair/Replace.”**
- f. Check to see that there is a drain (discharge) pipe attached to the relief valve. The pipe must be piped to within 18 inches of the floor, unthreaded and uncapped on the bottom end, and the same size as the relief valve outlet for the full length. The pipe must be of an approved material. If any of these conditions are not met mark this item as **“Below City Requirements.”** If the pipe is capped off or plugged mark this item as **“Repair/Replace.”**
- g. The evaluator is not required to test the relief valve, however if a visual inspection indicates that the relief valve could be inoperative, this condition shall be marked as **“Repair/Replace.”**

*NOTE: If the evaluator calls for certification of the furnace, a visual inspection and Orsat test are not acceptable. Approved testing methods are: smoke bomb test (combustion chamber and CO test), leak-seek test and CO test, and gas track – electronic sensor and CO test. If the furnace fails the combustion chamber integrity test, it must be replaced. CO test levels that exceed accepted safety standards would require the furnace/boiler to be repaired or serviced so that additional CO readings would be in the safe range. Complete documentation of repairs by a licensed heating or mechanical contractor including necessary permits is required.

22. Heating Plant Viewed in Operation

- A. The evaluator will attempt to operate the heating plant only during heating season (October 1 through May 15) by following these guidelines, and indicate in the space provided either “Y” for yes or “N” for no.
 - 1. The evaluator shall only operate the heating plant by turning up the thermostat. He/she is not required to light pilots or burners if they will not ignite by turning up the thermostat. If the heating plant has not been in operation for 30 days or more, the evaluator is exempt from conducting the operations test.

23. Heating Plant Combustion Venting

- A. Check to see that the vent lines are free of rust, holes and that the vent line runs uphill, the joints are tight and secured with 3 screws, and that the vent is tightly sealed to the chimney. If a loose heat shield is present it should be noted in the Comment column. The following conditions will be marked as **“Repair/Replace”**:
1. Holes caused by rusting or corrosion in the vent line.
 2. Vent line is not tightly sealed to the chimney.
 3. Vent line has gaps and/or is disconnected.

The following conditions will be marked as **“Below City Requirements”**:

1. Vent line does not run uphill.
 2. Vent connections do not have the proper number of screws at each connection.
 3. Improper materials used in vent line or stains from water entry.
- B. Determine that the vent line enters an approved chimney for the type of fuel used. If not, mark this item as **“Below City Requirements.”**
- C. If flues from separate gas appliances enter a chimney on opposite sides and are not offset in height mark as **“Repair / Replace.”**
- D. Check that the vent line has proper clearance to combustibles. If the clearance is not adequate mark this item as **“Repair/Replace.”**
- E. If there are any un-vented gas space heater(s), mark as **“Repair/Replace.”**

24. Auxiliary Heating Units

- A. Follow the guidelines for Items 21 through 23. This evaluation will include the visible venting and clearance to combustibles for wood stoves and fireplaces.

Additional Comments

- B. The evaluator shall check that all habitable rooms are provided with a heat register, a radiator or other direct heat source. If any habitable room lacks an observable heat source, this condition should be noted in the Comments column.

KITCHEN

25. Wall & Ceiling Components

- A. Visually inspect all walls and ceilings to determine if there are any areas of loose plaster, holes or blistering paint, or any damaged or incomplete components or if components are not kept in a workman like state of repair. Mark any deficiencies as **“Below City Requirements.”**
- B. If the evaluator estimates that there is the potential for structural failure of a wall or ceiling, mark as **“Repair/Replace.”**

26. Walls & Ceilings – Evidence of Dampness or Staining

- A. Check the entire room, including walls and ceilings, for evidence of water seepage or dampness and mark either **“Yes”** or **“No”** on the form. If **“Yes”** is marked put a **“C”** in the appropriate space and elaborate in the Comments column.
- B. If walls and/or ceiling have been obviously patched, this should be recorded by marking it as **“C”** and elaborate in the Comments column.

27. Floor (Structural)

- A. By visual inspection, determine if the floor is structurally sound, free of holes, and capable of supporting the loads normally imposed on it. If the evaluator estimates that there is the potential for structural failure of the floor system, mark as **“Repair/Replace.”**

- B. Deficiencies and/or damage in the floor shall be marked as “**Below City Requirements.**” “**Comment**” on any apparent out-of-level floors.
- C. The evaluator is not required to evaluate the condition of any floor coverings, unless their condition poses a potential risk through traffic areas, in which case it should be marked as “**Suggested Correction**” or “**Below City Requirements.**” The evaluator may mark it as “**Repair/Replace**” if there is a serious tripping hazard such as loose flooring materials or a 1 inch offset or greater.

28. Window Size & Operational Area

- A. Determine if the kitchen is provided with the required window area for light and operational area for ventilation for a habitable room, except where an approved mechanical ventilation system has been provided. Window area must equal a minimum of eight percent (8%) of the floor area of a habitable room. Open able area must equal a minimum of four percent (4%) of the floor area of the room. Approved mechanical ventilation complying with the Minnesota State Building Code is an acceptable alternative. If sufficient opening does not exist mark as “**Below City Requirements.**”
- B. If the kitchen is windowless, the evaluator shall determine if a proper opening exists between the windowless kitchen and the adjoining habitable room. At least fifty percent (50%) of the common wall must be open and unobstructed. The evaluator must then determine if the adjoining room has sufficient window area to meet the light and ventilation requirements for both rooms. Windowless kitchens must be provided with a mechanical vent. If sufficient opening does not exist mark as “**Below City Requirements.**”

29. Window & Door Condition

- A. Determine if the windows and doors have been kept in a professional state of repair, including the condition of the paint, glazing and missing locks. Note if decay or rotting is evident. If these conditions exist mark as “**Below City Requirements.**”
- B. Mark as “**Below City Requirements**” on any cracked panes of glass in windows, unless the exposed edges present a cut hazard, in which case the item should be marked as “**Repair/Replace.**”
- C. All windows that are easily accessible must be evaluated. Windows, other than a fixed window, shall be operational and capable of being held in position by window hardware. If the window is not accessible mark it with a “**C**” and comment on it in the Comments column.

30. Electric Outlets & Fixtures

Determine if the minimum number of electrical outlets and fixture as previously specified in *Item #19 for the guidelines of how to evaluate this area.*

- A. The evaluator shall determine if all visible outlets and fixtures and wiring have any missing and/or damaged components. If these missing or damaged components present an immediate potential for electric shock, mark this item as “**Repair/Replace.**” If no immediate potential for shock exists, mark this item as “**Below City Requirements.**”
 - 1, If light fixtures are nonfunctional due to lack of bulbs or due to nonfunctional bulbs, mark this as “**C**” and elaborate in the Comments column of the report.
- B. Mark as “**Below City Requirements**” any light fixture located within eighteen (18) inches of a shelf that does not have a protective globe.

31. Plumbing Fixtures/Mechanical Ventilation

- A. Determine if the kitchen is provided with a kitchen sink in good working condition and properly connected to a hot and cold water supply and a sewage system. If not, mark as “**Repair/Replace.**”
- B. In addition to the visual inspection of the vent pipe, the following evaluation should be made:
 - 1. Plug the drain and any overflow.
 - 2. Fill the fixture with 4”-6” of water.
 - 3. Remove the drain plug. If a gurgling is heard after the water has drained out, this could indicate no vent or defective vent. The evaluator should mark Item 31 as “**Below City Requirements**” and with a “**C**” and comment “**test indicates problem with venting.**”
- C. Check for repairs made with improper materials (tape, tar, rags, putty, etc.), if found mark as “**Suggested Correction.**” If repairs show signs of leaks or permit entrance of sewer gas mark as “**Repair/Replace.**”

- D. If any faucet discharge openings are located below the spill level of the plumbing fixture mark this item as **"Below City Requirements."**
- E. Mark any plumbing fixtures that are broken, cracked, leaking or in such condition as to give rise to unsanitary conditions as **"Repair/Replace."** **"Comment"** on dripping faucets.
- F. The evaluator will determine if any abandoned drain lines are properly capped. If they are not, mark as **"Repair/Replace."**
- G. If the kitchen is provided with a mechanical exhaust, the evaluator shall determine if the unit is operational. If not, mark as **"Below City Requirements."** The evaluator shall determine if the range exhaust, if designed to go to the outside, is continuous and metallic ductwork or equivalent, and must vent directly to the outside. If this system does not meet these requirements, mark as **"Below City Requirements."** If there is a recirculation fan, turn it on to make sure that it is functioning. If it is not, mark it as **"Below City Requirements."**

32. Water Flow

- A. The evaluator will check the flow of water to the plumbing fixture by opening the lowest faucet, the laundry tub cold-water faucet or the lawn faucet (sill cock), to its maximum capacity, and then test the hot and cold-water flow to the fixture by turning on the faucet.
 - 1. If the flow is interrupted, intermittent or there is no flow or the flow is not of an acceptable amount (pencil width), mark this item as **"Repair/Replace."**
 - 2. If the water flow just meets the minimum flow test, it should be noted in the **"Comments"** column that the flow is minimal.
 - 3. If there is no water flow mark this as **"Repair/Replace."** If the water is off, mark this item as **"Repair/Replace"** and **"Comment"** in the comment column "Water is off."

33. Gas Piping

Refer back to Item #11 and follow those guidelines to evaluate this area.

DINING ROOM & LIVING ROOM

34. Walls & Ceiling Components

- A. The evaluator shall make a visual inspection of the walls and ceilings. Areas of loose or broken plaster or wall finishes, excessively cracked gypsum board, unsanitary conditions or other deficiencies of the walls and ceilings shall be marked as **"Below City Requirements."**
- B. The evaluator is not responsible for determining the condition of wallpaper, paint and other obvious cosmetic items.
- C. If the evaluator estimates that there is the potential for structural failure of a wall or ceiling; mark this item as **"Repair/Replace."**

35. Walls & Ceilings - Evidence of Dampness or Staining

- A. The evaluator shall check the entire room, including walls and ceilings, for evidence of water seepage or dampness and mark either **"Yes"** or **"No"** on the form. If **"Yes"** is indicated, elaborate in the **"Comments"** column.
- B. If walls and/or ceiling have been obviously patched, this should be recorded in the **"Comments"** column.

36. Floor Areas & Ceiling Height

All the room classifications set out here must be deemed to be used for living and thus must meet the minimum size requirements for habitable rooms along with the minimum ceiling height, window area and other such standards as set out in the City of Robbinsdale's Property Maintenance Code. The City of Robbinsdale's Property Maintenance Code provides that all habitable rooms, other than kitchens, have a minimum of 70 square feet of floor area. Habitable rooms, other than kitchens, must also be at least 7 feet in any dimension. The minimum ceiling for habitable spaces, hallways, corridors, laundry areas, bathrooms, toilet rooms and habitable basement areas, is not less than 7 feet. The evaluator shall keep these minimum

standards in mind when evaluating habitable spaces and mark any room not meeting these standards as **“Below City Requirements.”**

37. Floor (Structural)

- A. Deficiencies and/or damage in floor shall be marked as **“Below City Requirements.”** **“Comment”** on any apparent out-of-level floors.
- B. By visual inspection, determine if the floor is structurally sound, free of holes and capable of supporting normal loads imposed on such floor. If any of these conditions exist mark this item as **“Below City Requirements.”** If there is a potential for structural failure mark this item as **“Repair/Replace.”**
- C. The evaluator is not required to evaluate the condition of any floor coverings, unless their condition poses a potential risk through traffic areas, in which case it should be marked as **“Suggested Correction”** or **“Below City Requirements.”** The evaluator may mark it as **“Repair/Replace”** if there is a tripping hazard.

38. Window Size & Operational Area

- A. Determine if rooms are provided with required window area for light, and also the required operational area for ventilation. Window area must equal a minimum of 8% of the floor area of the room. Operational area must equal a minimum of 4% of the floor area of the room. Approved mechanical ventilation complying with the Minnesota State Building Code is an acceptable alternative. If these minimums are not met, mark this item as **“Below City Requirements.”**

39. Window & Door Condition

- A. Determine if the windows and doors have been kept in a professional state of repair, including the condition of the paint glazing and missing locks. Note if decay or rotting is evident. If these conditions exist mark as **“Below City Requirements.”**
- B. Mark as **“Below Minimum Standards”** on any cracked panes of glass in windows, unless they expose edges that present a cut hazard, in which case the item should be marked as **“Repair/Replace.”**
- C. All windows that are easily accessible must be evaluated. Windows, other than a fixed window, shall be operational and capable of being held in position by window hardware. If the window is not accessible mark it with a **“C”** and comment on it in the **Comments** column. Mark as **“Below Minimum Standards”** any window that does not operate properly (i.e. sashes are painted shut, crank out windows that do not open, etc.).
- D. Mark as **“Below City Requirements”** any window that does not operate properly (i.e. sashes are painted shut, crank out windows that do not open, etc.). If window drops hard or needs to be propped open it should be marked **“Suggested Correction.”**

40. Electrical Outlets & Fixtures

Refer to Item #19 for instructions on how to evaluate the electrical outlets and fixtures for this area.

BATHROOMS

If there is more than one bathroom, “Comment” in the Comment column to identify which bathroom rating(s) belong.

41. Walls & Ceiling Components

- A. The evaluator shall make a visual inspection of the walls and ceilings. Areas of loose or broken plaster or wall finishes, excessively cracked gypsum board, unsanitary conditions or other deficiencies of the walls and ceilings shall be marked as **“Below City Requirements.”**
- B. The evaluator is not responsible for determining the condition of wallpaper, paint and other obvious cosmetic items.

- C. If the evaluator estimates that there is the potential for structural failure of a wall or ceiling, mark this item as **“Repair/Replace.”**

42. Walls & Ceilings - Evidence of Dampness or Staining

- A. The evaluator shall check the entire room, including walls and ceilings, for evidence of water seepage or dampness and mark either **“Yes”** or **“No”** on the form. If **“Yes”** is indicated, elaborate in the **“Comments”** column.
- B. If walls and/or ceiling have been obviously patched, this should be recorded in the **“Comments”** column.

43. Floor (Structural)

- A. Deficiencies and/or damage in floor shall be marked as **“Below City Requirements.”** **“Comment”** on any apparent out-of-level floors.
- B. By visual inspection, determine if the floor is structurally sound, free of holes and capable of supporting normal loads imposed on such floor. If any of these conditions exist mark this item as **“Below City Requirements.”** If there is a potential for structural failure mark this item as **“Repair/Replace.”**
- C. The evaluator is not required to evaluate the condition of any floor coverings, unless their condition poses a potential risk through traffic areas, in which case it should be marked as **“Suggested Correction”** or **“Below City Requirements.”** The evaluator may mark it as **“Repair/Replace”** if there is a tripping hazard.

44. Window Size/Operational Area/Mechanical Exhaust

- A. Determine if rooms are provided with required window area for light, and also the required operational area for ventilation. Window area must equal a minimum of 8% of the floor area of the room. Operational area must equal a minimum of 4% of the floor area of the room. Approved mechanical ventilation complying with the Minnesota State Building Code is an acceptable alternative. If these minimums are not met, mark this item as **“Below City Requirements.”**
- B. If the bathroom is windowless, the evaluator shall determine if the mechanical ventilation system is continuous to the outside. If the system does not vent directly to the outside, mark this as **“Below City Requirements.”**

45. Window & Door Condition

- A. Determine if the windows and doors have been kept in a professional state of repair, including the condition of the paint, glazing, and missing locks. Note if decay or rotting is evident. If these conditions exist mark as **“Below City Requirements.”**
- B. Mark as **“Below City Requirements”** on any cracked panes of glass in windows, unless they expose edges that present a cut hazard, in which case the item should be marked as **“Repair/Replace.”**
- C. All windows that are easily accessible must be evaluated. Windows, other than a fixed window, shall be operational and capable of being held in position by window hardware. If the window is not accessible mark it with a **“C”** and comment on it in the Comments column.
- D. Mark as **“Below City Requirements”** any window that does not operate properly (i.e. sashes are painted shut, crank out windows that do not open, etc.).
- E. Determine if going through a bedroom is the only access to a common bathroom and record that fact in **“Comment”** column.

46. Electrical Outlets & Fixtures

- A. Every bathroom shall contain at least one receptacle. If it does not, mark this item as **“Below City Requirements.”**

Refer to Item #19 for instructions on how to evaluate the electrical outlets and fixtures for this area.

47. Plumbing Fixtures

- A. The evaluator shall determine if the bath or toilet room is provided with the minimum number of plumbing fixtures required by the City of Robbinsdale's Property Maintenance Code. The minimum requirement is that each dwelling unit shall have its own bathtub or shower, lavatory and water closet. The lavatory shall be placed in the same room as the water closet or located in close proximity to the door leading directly into the room in which such water closet is located. If the dwelling unit does not comply with these minimum requirements, mark as **"Repair/Replace."**
- B. Determine if the bathtub or shower and the hand lavatory are properly connected to the source of hot and cold water and properly connected with the sewer system, and if not, mark as **"Repair/Replace."**
- C. In addition to the visual inspection of the vent pipe, the following evaluation should be made:
 - 1. Put the plug or strainers in the drain.
 - 2. Fill the fixture with 4"-6" of water.
 - 3. Remove the drain plug. If a gurgling is heard after the water has drained out, this could indicate no vent or defective vent. The evaluator should mark Item 47 as **"Below City Requirements"** and with a **"C"** and comment **"test indicates problem with venting."**
 - 4. Plug drain and any overflow.
- D. Check for repairs made with improper materials (tape, tar, rags, putty, etc.), if found mark as **"Below City Requirements."** If repairs show signs of leaks or permit entrance of sewer gas mark as **"Repair/Replace."**
 - 1. If any faucet discharge openings are located below the spill level of the plumbing fixture mark this item as **"Below City Requirements."**
- E. Mark any plumbing fixtures that are broken, cracked, leaking or in such condition as to give rise to unsanitary conditions as **"Repair/Replace."** **"Comment"** on dripping faucets.
- F. Determine if the required water closet is properly connected to a water supply, is provided with an anti-siphon ball cock and is properly connected to a sewage system. If any of these items are missing, mark as **"Below City Requirements."**
- G. If a handheld shower device drops below the spill line of the tub, mark as **"Below City Requirements."** If a handheld shower has a permanently mounted hold that secures the device above the spill line, the evaluator need only **"Comment."**
- H. Determine if access to the tub plumbing connections is provided, if not mark as **"Below City Requirements."**

48. Water Flow

- A. The evaluator will check the flow to the plumbing fixture by opening the lowest faucet, the laundry tub cold-water faucet or the lawn faucet (sill cock), to its maximum capacity, and then test the hot and cold-water flow to the fixture by turning on the faucet.
 - 1. If the flow is interrupted, intermittent or there is no flow or the flow is not of an acceptable amount (pencil width), mark this item as **"Repair/Replace."**
 - 2. If the water flow just meets the minimum flow test, it should be noted in the **"Comments"** column that the flow is minimal.

HALLWAYS & STAIRWELLS

49. Walls & Ceiling Components

- A. The evaluator shall make a visual inspection of the walls and ceilings. Areas of loose or broken plaster or wall finishes, excessively cracked gypsum board, unsanitary conditions or other deficiencies of the walls and ceilings shall be marked as **"Below City Requirements."**

- B. The evaluator is not responsible for determining the condition of wallpaper, paint and other obvious cosmetic items.
- C. If the evaluator estimates that there is the potential for structural failure of a wall or ceiling, mark this item as **“Repair/Replace.”**

50. Walls & Ceilings - Evidence of Dampness or Staining

- A. The evaluator shall check the entire room, including walls and ceilings, for evidence of water seepage or dampness and mark either **“Yes”** or **“No”** on the form. If **“Yes”** is indicated, elaborate in the **“Comments”** column.
- B. If walls and/or ceiling have been obviously patched, this should be recorded in the **“Comments”** column.

51. Floor (Structural)

- A. Deficiencies and/or damage in floor shall be marked as **“Below City Requirements.”** **“Comment”** on any apparent out-of-level floors.
- B. By visual inspection, determine if the floor is structurally sound, free of holes and capable of supporting normal loads imposed on such floor. If any of these conditions exist mark this item as **“Below City Requirements.”** If there is a potential for structural failure mark this item as **“Repair/Replace.”**
- C. The evaluator is not required to evaluate the condition of any floor coverings, unless their condition poses a potential risk through traffic areas, in which case it should be marked as **“Suggested Correction”** or **“Below City Requirements.”** The evaluator may mark it as **“Repair/Replace”** if there is a tripping hazard.

52. Window & Door Condition

- A. Determine if the windows and doors have been kept in a professional state of repair, including the condition of the paint glazing and missing locks. Note if decay or rotting is evident. If these conditions exist mark as **“Below City Requirements.”**
- B. Mark as **“Below City Requirements”** on any cracked panes of glass in windows, unless they expose edges that present a cut hazard, in which case the item should be marked as **“Repair/Replace.”**
- C. All windows that are easily accessible must be evaluated. Windows, other than a fixed window, shall be operational and capable of being held in position by window hardware. If the window is not accessible mark it with a **“C”** and comment on it in the comments column.
- D. Mark as **“Below City Requirements”** any window that does not operate properly (i.e. sashes are painted shut, crank out windows that do not open, etc.).

53. Electrical Outlets & Fixtures

Refer to Item #19 for instructions on how to evaluate the electrical outlets and fixtures for this area.

54. Stairs, Upper Floors

- A. Determine if the stairway(s) leading to the upper floors and the attic are safe to use and capable of supporting the normal loads and use placed upon them. If they are not, mark this item as **“Below City Requirements.”** If the evaluator determines that there is a potential for structural failure, this item will be marked as **“Repair/Replace.”**
- B. Determine if the stair rise (8” maximum), run (9” minimum), and width (36”) are proper. Determine if the rise and run of the treads are even and/or uniform (see section 1C). If any of these conditions are not met this item will be marked as **“Below City Requirements.”**
- C. If the stairway has an open side it must have a guardrail that is a minimum of 36” in height with intermediate rails that are spaced so that a 4 3/8” sphere cannot pass through the openings. If either of these criteria is not met it should be marked as **“Below City Requirements.”**

55. Smoke/Carbon Monoxide Detectors

Guidelines are the same as listed in item #17. Installation shall be as required by State Statue 229F.362 POLICY # INS 199-14.

Carbon Monoxide detectors shall be installed within 10 feet of each room used for sleeping in accordance Minnesota Statute 299F.50. If Carbon Monoxide Detectors are not present, mark “**Suggested Correction.**”

SLEEPING ROOMS

56. Number of Sleeping Rooms (include basement units)

- A. Indicate the total number of sleeping rooms in the dwelling unit.
- B. Determine if sleeping rooms meet City of Robbinsdale’s Property Maintenance Code requirements for size, ceiling height, proper location, emergency egress, and natural light and ventilation. If any room being used as a sleeping room does not meet the minimum requirements, mark as “**Below City Requirements**”, **except if the room lacks an emergency egress window then it must be marked as “Repair/Replace.”**

Note: If an evaluator believes that a room is being used for sleeping purpose, the evaluator should count it as a sleeping room and mark it on the form and evaluate it as such.

57. Walls & Ceiling Components

- A. The evaluator shall make a visual inspection of the walls and ceilings. Areas of loose or broken plaster or wall finishes, excessively cracked gypsum board, unsanitary conditions or other deficiencies of the walls and ceilings shall be marked as “**Below City Requirements.**”
- B. The evaluator is not responsible for determining the condition of wallpaper, paint and other obvious cosmetic items.
- C. If the evaluator estimates that there is the potential for structural failure of a wall or ceiling, mark this item as “**Repair/Replace.**”

58. Walls & Ceiling - Evidence of Dampness or Staining

- A. The evaluator shall check the entire room, including walls and ceilings, for evidence of water seepage or dampness and mark either “**Yes**” or “**No**” on the form. If “**Yes**” is indicated, elaborate in the “**Comments**” column. If walls and/or ceiling have been obviously patched, this should be recorded in the “**Comments**” column.

59. Floor Area

- A. Determine if all sleeping rooms have the required floor area and ceiling height. Referred to by Appendix 3 for specific floor area requirements. If these requirements are not met, mark as “**Below City Requirements.**”

60. Floor (Structural)

- A. Deficiencies and/or damage in floor shall be marked as “**Below City Requirements.**” “**Comment**” on any apparent out-of-level floors.
- B. By visual inspection, determine if the floor is structurally sound, free of holes and capable of supporting normal loads imposed on such floor. If any of these conditions exist mark this item as “**Below City Requirements.**” If there is a potential for structural failure mark this item as “**Repair/Replace.**”
- C. The evaluator is not required to evaluate the condition of any floor coverings, unless their condition poses a potential risk through traffic areas, in which case it should be marked as “**Suggested Correction**” or “**Below City Requirements.**” The evaluator may mark it as “**Repair/Replace**” if there are tripping hazards.

61. Window Size & Operational Area

- A. Determine if rooms are provided with required window area for light, and also the required operational area for ventilation. Window area must equal a minimum of 8% of the floor area of the room. Operational area must equal a minimum of 4% of the floor area of the room. Approved

mechanical ventilation complying with the Minnesota State Building Code is an acceptable alternative. If these minimums are not met, mark this item as “**Below City Requirements.**”

- B. Determine if the windows in sleeping rooms meet the escape window requirements (Egress Code) in effect at the time of construction or remodeling. If not mark this item as “**Below City Requirements.**”

1. At least one (1) window in every room used for sleeping purposes must be operational from the inside, with a minimum net glazed area of five (5.0 square feet); the minimum net clear opening height dimension shall be twenty-two (22 inches), the minimum net clear opening width shall be twenty (20) inches, and it shall have a minimum finished sill height of not more than forty-eight (48) inches above the floor.

A window or other opening located such that the sill height of the opening is not more than 44 inches above or below the finished ground level adjacent to the opening may have a minimum net clear opening of 5 square feet

Replacement windows in sleeping rooms are allowed to have the existing height and width net clear opening reduced provided the replacement window is the manufacture’s largest standard size window, of the same type, that will fit within the existing frame or rough opening.

Exception: Reduction in is size is not allowed when any of the following conditions apply:

- a) The rooms or areas are used for any Minnesota state licensed purpose.
 - b) The dwelling is rental property. Egress windows for rental property shall comply with the Robbinsdale Housing Maintenance Code.
2. Should the window, or any part of it, be below grade, an excavation shall be made, on the exterior side of the window that extends at least to the depth of the sill. The clear horizontal dimensions shall allow the window to be fully opened and provide a minimum accessible net clear opening of 9 square feet with a minimum dimension of 36 inches. If the windowsill is forty-four (44) inches or more below grade, a permanently affixed ladder or stairs that are accessible with the window fully open position shall be provided. The ladder or stairs shall not encroach into the required dimensions of the window well by more than 6 inches.
3. A door leading directly to the outside and providing an exit at grade for the sleeping room only, may be used in lieu of the specified window.

62. Window & Door Condition

- A. Determine if the windows and doors have been kept in a professional state of repair, including the condition of the paint glazing and locks. Note if decay or rotting is evident. If these conditions exist mark as “**Below City Requirements.**”
- B. Mark as “**Below City Requirements**” on any cracked panes of glass in windows, unless they expose edges that present a cut hazard, in which case the item should be marked as “**Repair/Replace.**”
- C. All windows that are easily accessible must be evaluated. Windows, other than a fixed window, shall be operational and capable of being held in position by window hardware. If the window is not accessible, mark it with a “**C**” and comment on it in the comments column.
- D. Mark as “**Below City Requirements**” any window that does not operate properly (i.e. sashes are painted shut, crank out windows that do not open, etc.).

63. Electrical Outlets & Fixtures

Refer to Item #19 for instructions on how to evaluate the electrical outlets and fixtures for this area. City of

PORCH – SUNROOM – OTHER

The evaluator will identify each room and comment separately when needed. This category includes all other rooms not previously evaluated, such as dens, sewing rooms, studies, nurseries and libraries, etc.

where appropriate. All the room classifications set out here must be deemed to be used for living and thus must meet the minimum size requirements, the minimum ceiling height, window area and other such standards for habitable rooms as set out in the City of Robbinsdale's Property Maintenance Code.

64. Walls & Ceiling Components

- A. The evaluator shall make a visual inspection of the walls and ceilings. Areas of loose or broken plaster or wall finishes, excessively cracked gypsum board, unsanitary conditions or other deficiencies of the walls and ceilings shall be marked as **"Below City Requirements."**
- B. The evaluator is not responsible for determining the condition of wallpaper, paint and other obvious cosmetic items.
- C. If the evaluator estimates that there is the potential for structural failure of a wall or ceiling, mark this item as **"Repair/Replace."**

65. Walls & Ceiling – Evidence of Dampness or Staining

- A. The evaluator shall check the entire room, including walls and ceilings, for evidence of water seepage or dampness and mark either **"Yes"** or **"No"** on the form. If **"Yes"** is indicated, elaborate in the Comments column.
- B. If walls and/or ceiling have been obviously patched, this should be recorded in the **"Comments"** column.

66. Floor (Structural)

- A. Deficiencies and/or damage in floor shall be marked as **"Below City Requirements."** **"Comment"** on any apparent out-of-level floors.
- B. By visual inspection, determine if the floor is structurally sound, free of holes and capable of supporting normal loads imposed on such floor. If any of these conditions exist mark this item as **"Below City Requirements."** If there is a potential for structural failure mark this item as **"Repair/Replace."**
- C. The evaluator is not required to evaluate the condition of any floor coverings, unless the condition poses a potential risk through traffic areas, in which case it should be marked as **"Suggested Correction"** or **"Below City Requirements."** The evaluator may mark it as **"Repair/Replace"** if there is a serious tripping hazard.

67. Window & Door Condition

- A. Determine if the windows and doors have been kept in a professional state of repair, including the condition of the paint glazing and locks. Note if decay or rotting is evident. If these conditions exist mark as **"Below City Requirements."**
- B. Mark as **"Below City Requirements"** on any cracked panes of glass in windows, unless they expose edges that present a cut hazard, in which case the item should be marked as **"Repair/Replace."**
- C. All windows that are easily accessible must be evaluated. Windows, other than a fixed window, shall be operational and capable of being held in position by window hardware. If the window is not accessible mark it with a **"C"** and comment on it in the Comments column.
- D. Mark as **"Below City Requirements"** any window that does not operate properly (i.e. sashes are painted shut, crank out windows that do not open, etc.).

68. Electrical Outlets & Fixtures

Refer to Item #19 for instructions on how to evaluate the electrical outlets and fixtures for this area.

ATTIC SPACE

69. Roof Board, Rafters & Insulation

- A. If the evaluator is unable to gain visual access to the attic space(s) this **must** be noted **and the reason for not gaining access must** be detailed in the **Comment** column of the report.
- B. Make a visual inspection of the underside of the roof boards and rafters, recording any defects and/or deficiencies in the roof structure as “**Below City Requirements.**” If the evaluator determines that there is potential for structural failure including active leaking, this item will be marked as “**Repair/Replace.**”
- C. Determine if the mechanical ventilation system provided for the bath, toilet or kitchen rooms is continuous to the outside. If these vents are not, mark as “**Below City Requirements.**”
- D. Inspect the condition of the visible chimney in the attic areas for deterioration, holes or other visible defects. If the chimney appears to be structurally adequate, but has other visible defects, mark as “**Below City Requirements.**” If the chimney appears to be structurally unsafe, mark as “**Repair/Replace.**”
- E. Determine if attic insulation is provided. If “**Yes**” indicate the type and depth. If unable to view attic insulation, note this in the Comments column.

70. Evidence of Dampness or Staining

Determine whether there is evidence of past water seepage or leakage and indicate either “**Yes**” or “**No**” on the form. If “**Yes**” is indicated, elaborate in the Comments column.

71. Electrical Outlets & Fixtures

Refer to Item #19 for instructions on how to evaluate the electrical outlets and fixtures for this area.

EXTERIOR

72. Foundation

- A. Determine if all visible components of the foundation are in a professional state of repair. Missing or damaged mortar, broken/loose or missing block or brick shall be marked as “**Below City Requirements.**” Damaged or loose plaster/stucco on foundation or exposed foam insulation shall be marked “**Below City Requirements.**” Evidence of severe structural damage or deterioration shall be marked as “**Repair/Replace.**”
- B. Note if there are trees or shrubs growing next to the foundation. Mark as “**Below City Requirements**” if present.
- C. If brick, stucco, snow, vegetation, etc. conceal areas, indicate with a “**Comment**” (e.g., “areas concealed by vegetation”, “Can’t view to evaluate”, or other description of condition(s) present which prevent viewing to evaluate.).

73. Basement Windows

- A. Determine if the windows/doors have been kept in a professional state of repair, including the condition of the paint glazing and locks. Note if decay or rotting is evident. If these conditions exist mark as “**Below City Requirements.**” Any sign of rot, decay or lack of a weather resistant finish shall be marked as “**Below City Requirements.**”
- B. Mark as “**Below City Requirements**” on any cracked panes of glass in windows, unless they expose edges that present a cut hazard, in which case the item should be marked as “**Repair/Replace.**”

74. Drainage

Determine if the grade allows water migration away from the dwelling. Consider sidewalks and down spout extensions, basement windows, stairways, stoops, retaining walls and planting areas, when making this determination. If drainage is not away from structures, mark as “**Below City Requirements.**” The evaluator shall determine if grading conditions are such that they provide proper drainage away from the dwelling. If the grade does not allow surface water to drain away from the building, mark as “**Below City Requirements.**”

75. Exterior Walls

- A. Determine if all visible components of the exterior walls are protecting the dwelling against the elements, and are kept in a professional state of repair (look for rot, weathered or peeling paint). If not in a professional state of repair or if there is any damaged, missing, deteriorated or weathered siding, broken or damaged stucco, mark as **“Below City Requirements.”**
- B. Evidence of severe structural damage or deterioration shall be marked as **“Repair/Replace.”**
- C. **“Comment”** in the Comment column if no house numbers are present or if they are not easily observed and readable from the public right-of-way (See Appendix 2 in these guidelines).

76. Doors (Frames/Storms/Screens)

- A. Determine if all exterior doors of the dwelling are provided with a storm door, unless the primary door has an energy efficiency rating of R2. If not, mark as **“Below City Requirements.”**
- B. Determine if the doors have been kept in a professional state of repair, including the condition of the paint and glazing, and note if there are broken doorjambs, decay or rotting is evident. If substandard conditions exist, mark as **“Below City Requirements.”** Note broken or jagged glass that can cause cuts shall be marked as **“Repair/Replace.”**
- C. Check to see that all dwelling units have a dead bolt lock on all exterior doors and it is functioning. If the dead bolt does not meet these standards, mark as **“Below City Requirements.”** **“Comment”** on the presence of the double-keyed dead bolts.

77. Windows (Frames/Storms/Screens)

- A. Determine if the screens and storm windows have been kept in a professional state of repair, including the condition of the paint, screens, weep holes and glazing. Note if torn or missing screens, damaged or missing glazing, plugged weep holes, decayed wood is evident. If substandard conditions exist, mark as **“Below City Requirements.”** Mark as **“Repair/Replace”** if any broken or jagged glass that can cause cuts is found.
- B. The evaluator shall comment on the condition of the windows screens if present.

78. Stoops

- A. Determine if exterior stairways, porches, and other appurtenances have been constructed so as to be safe for normal use and loading and kept in a professional state of maintenance and repair. If conditions exist that these items are incapable of carrying normal loads, mark as **“Repair/Replace.”**
- B. The evaluator shall also determine if the stairway(s) rise, run and width are proper (Min. tread 9”, max. rise 8”, min. width 36”) and have an acceptable handrail where the stairs exceed 3 risers. If the stairway(s) do not meet these minimums, mark as **“Below City Requirements.”**

79. Cornice & Trim

Determine if the cornice and trim has been maintained in a professional manner and if the paint or finish meets the minimum standards of the City of Robbinsdale’s Property Maintenance Code, which pertains to protective surfaces, if not mark as **“Below City Requirements.”** If gutters are present they should be in working order without leaks or missing parts.

80. Roof Covering & Flashing

The evaluator is not required to use a ladder to observe the roof. The roof is to be viewed from the ground, upstairs windows, walkout deck or porches, or with the aid of binoculars. Check roof vents, sewer pipe covers, and sidewall and valley areas. All visible components must be kept in a professional state of repair. If not, mark as **“Below City Requirements.”**

- A. All components of the roof shall be tight and have no defects which admit rain. Roof drainage shall be adequate to prevent rainwater from causing dampness in the walls. If not, mark as **“Below City Requirements.”** Exposed edges of roof boards or plywood must be protected with wood fascia or metal drip edge. If not, mark as **“Below City Requirements.”**
- B. Broken, missing loose or deteriorated shingles, shakes, flashings or valley areas, excessive granular loss, cupping, and excessive rust or excessive tarring shall be marked as **“Below City Requirements.”** Tarring or improper repairs to valley areas or any buckling/curling of roofing materials shall be marked as **“Below City Requirements.”** Roll roofing used on less than 1/12

slope or shingles used on less than 2/12 slope shall be marked as “**Below City Requirements**” (e.g. improper roofing materials used on low slope roof). Pay special attention to low slope dormers, porches, etc.

- C. If the roof is snow covered, or if areas are not visible, note this with a “**Comment**” (examples: High or flat areas are not visible from ground, areas covered by decks, areas covered by outdoor carpet, areas covered by leaves, or flat areas covered by gravel. Can’t fully view roof areas from ground. Tar patching evident around penetrations, cannot view to evaluate. Roof has been coated, can’t evaluate. Sidewall flashings concealed by tar, can’t view to evaluate.).
- D. If tree limbs or branches are touching the roof, note this with a “**Comment.**”

81. Chimney

- A. Determine if all visible components of the chimney or chimneys have been kept in a workmanlike state of maintenance and repair (the evaluator is required to use binoculars). If not, mark as “**Below City Requirements.**”
- B. Note as “**Below City Requirements**” any chimney that leans, has loose brick or stone, cracked or missing brick/mortar or missing/damaged flashing. If the chimney is not structurally sound or in danger of collapse, mark as “**Repair/Replace.**”
- C. Determine if the chimney extends the appropriate height above the roof or adjacent obstructions. Class “A” chimneys must extend three feet minimum and 24 inches above anything within 10 feet. Class “B” chimneys on flat roofs must extend a minimum of 12 inches or 24 inches above anything within 8 feet. (This includes walls, parapets, etc.) Class “B” chimneys having an internal diameter of 12 inches or less shall extend at least 12 inches in all other areas. If the chimney does not obviously meet the requirements, mark as “**Below City Requirements.**”
- D. Determine if metal flue liner, or other approved flue liner, has been provided in the chimney when a gas-fired heating plant/appliance is used. If metal liner is deteriorated/rusted, mark as “**Below City Requirements.**”
- E. If no flue liner is visible from the ground, the evaluator shall note this information in the “**Comment**” section (no visible metal liner). All transite (asbestos) chimneys shall be marked as “**Below City Requirements**”, and if there is any visible deterioration it must be marked as “**Repair/Replace.**” If the chimney is not visible from the ground the evaluator must state the reason in the Comment column. (e.g. “Chimney not visible..” “...due to snow”, “...due to adjacent structures”, or, “upper roof area not visible from ground.”).
- F. If the flue was not evaluated make a “**Comment**” in the comment column with a statement that it was not checked with an explanation.

82. Electrical Outlets & Fixtures

- A. The evaluator shall determine if exterior lights, outlets, exterior outlet covers, switches, and fixtures are properly installed and maintained. If not, mark as “**Below City Requirements.**” Look for broken receptacles, switches, missing plates, and broken parts, if any of these items are found, mark as “**Repair/Replace.**”
- B. Determine if exterior electrical outlets exposed to the weather are provided with a weather-tight cover and are properly grounded. If not, mark this as “**Below City Requirements.**”
- C. Check all GFCI outlets using an electrical outlet-testing device. If any GFCI outlet is improperly installed, mark as “**Below City Requirements.**” If exterior mast is broken or improperly secured to building mark as “**Repair/Replace.**”
- D. Check the condition of the electrical service drop wires. Check for the proper minimum clearance from building openings, above recreational areas or walk able surface(s) (decks, stairways, play structures, etc.) and over driveways (8.5 feet above recreational areas or walkable surface(s), 10 feet above driveways, three feet from any opening). If not, mark as “**Repair/Replace.**” If the clearance between electrical service drop wires and recreational areas or walkable surfaces is between 8.5 and 10 feet, mark as “**Suggested Correction**” and provide “**Comment.**” Any service/electrical wires not complying with the 2005 National Electric Code Section 680.8A above pools or hot tubs shall be marked as “**Below City Requirements**” and provide “**Comment.**”
- E. The evaluator shall determine that all fixtures, including florescent lights, designed to have a globe or protective device covering the bulb, are covered as required. If not, mark as “**Below City Requirements.**”
- F. If overhead electrical wires are touched by trees or branches, mark as “**Suggested Correction.**”

83. Two-Family Dwelling Egress

- A. Determine if proper private egress is provided from the two-family dwelling (two independent exits). If not, mark as “**Below City Requirements.**”

OPEN/UNHEATED TYPE PORCHES

84. Floor (Structural)

- A. Deficiencies and/or damage in floor shall be marked as “**Below City Requirements.**” “**Comment**” on any apparent out-of-level floors.
- B. By visual inspection, determine if the floor is structurally sound, free of holes and capable of supporting normal loads imposed on such floor. If any of these conditions exist mark this item as “**Below City Requirements.**” If there is a potential for structural failure mark this item as “**Repair/Replace.**”
- C. The evaluator is not required to evaluate the condition of any floor coverings, unless their condition poses a potential risk through traffic areas, in which case it should be marked as “**Suggested Correction**” or “**Below City Requirements.**” The evaluator may mark it as “**Repair/Replace**” if there is a serious tripping hazard.

85. Walls (Structural)

- A. Visually check the walls for leaning, buckling, and bulging conditions, which would indicate structural failure. If the evaluator estimates that there is the potential for structural failure, mark as “**Repair/Replace.**”
- B. Mark as “**Below City Requirements**” if there are any loose plaster, holes or blistering paint and/or texture. The evaluator is not responsible for determining the condition of wallpaper, paint and other cosmetic items.
- C. If the evaluation reveals that all or a portion of the walls is covered, mark as “**Comment**” and explain.

86. Roof (Structural)

- A. The evaluator is not required to use a ladder to observe the roof. The roof is to be viewed from the ground, upstairs windows, walkout deck or porches, or with the aid of binoculars. Check roof vents, sewer pipe covers, and sidewall and valley areas. All visible components must be kept in a professional state of repair. If not, mark as “**Below City Requirements.**”
- B. Check the condition of the rafters and sheathing. If these areas are not visible, note this with a “**Comment.**” If the evaluator estimates that there is the potential for structural failure of the rafters and/or sheathing, mark as “**Repair/Replace.**”

87. Doors/Screens/Windows

Determine if the doors, screens, and windows have been kept in a professional state of repair, including the condition of the paint and glazing, and note if there are broken doorjamb, decay or rotting is evident. If substandard conditions exist, mark as “**Below City Requirements.**” The evaluator shall note broken or jagged glass that can cause cuts shall be marked as “**Repair/Replace.**”

88. Electrical Outlets & Fixtures

- A. Determine if porch lights, outlets, switches and fixtures are properly installed and maintained. If not, mark as “**Below City Requirements.**”
- B. Visually check for broken receptacles, switches, missing plates and broken parts. If any of these items are found mark as “**Repair/Replace.**”
- C. Check all GFCI outlets using an electrical outlet-testing device. If any outlet is improperly installed, mark as “**Below City Requirements.**”

GARAGE

If the garage is locked or not accessible, re-inspection is necessary to complete evaluation. Call the same evaluator for re-inspection, additional fees and comments may be necessary.”

89. Structure & Roof

The evaluator shall follow the same procedural guidelines as set out in Item 80 to evaluate the **structure and** roof covering and flashing. The evaluator shall determine the condition of the rafters and roof sheathing from inside the garage. If the evaluator estimates that there is a potential for structural failure of the structure or roof or if the roof leaks, mark as **”Suggested Correction.”**

90. Wall Structure & Covering

- A. Determine if all visible components of the garage foundation, walls and windows have been kept in a workmanlike state of construction, maintenance and repair. Any sign of rot or decay, lack of proper finish, weathered/peeling paint or loose/missing glazing shall be marked as **”Below City Requirements.”**
- B. Deteriorated, missing, excessively weathered or rotted siding on the garage shall be marked as **”Below City Requirements.”** Stucco cracks, missing mortar or damaged block shall be marked as **”Below City Requirements.”**
- C. If the garage is attached to the house, the common wall shall be properly fire protected, with no openings, access panels, dryer vents or damaged areas. If not, mark as **”Suggested Correction.”**
- D. If any exterior parallel wall of a detached garage is less than six (6) feet from the wall of the dwelling, item C shall apply.
- E. **”Comment”** if there are no house numbers on the front of the house or if they do not meet the requirements of City of Robbinsdale’s Property Maintenance Section 405 IPMC 303.3 (See Appendix 2).
- F. Heating systems in garages shall be evaluated in accordance with sections 21, 22, 23 and 24.

91. Garage Doors

- A. Determine if all visible components of the garage are maintained in a sound, professional state of maintenance and repair. Any sign of damage, rot or decay, or lack of proper finish (peeling paint/excessive weathering) shall be marked as **”Below City Requirements.”**
- B. If the garage is attached to the house, the door between the house and garage must be solid core wood, a minimum of 1-3/8 inches thick, or a rated metal door. If these conditions are not present, mark as **”Below City Requirements.”**
- C. Test the automatic garage door opener, if there is one present. Test the reverse mechanism on the door by blocking the light beam. If the door does not have a light beam, test the door opener by placing an object under the middle of the door and allow the door to close. If the reverse mechanism does not work, mark as **”Suggested Correction”** or **”Below City Requirements.”**

92. Electrical Outlets & Fixtures

- A. Determine if all components of the existing electrical wiring in any accessory structure are installed in an approved manner, and have been properly maintained. Extension cord wiring cannot be used in lieu of permanent wiring (garage door openers, lights, etc.). Mark as **”Repair/Replace”** if any extension cords are being used as permanent wiring.
- B. Any exposed wiring, missing plates, missing knockouts, open junction boxes or improperly terminated wires shall be marked as **”Repair/Replace.”**
- C. Determine if the electrical wires leading to an accessory structure are located at an acceptable minimum height above grade and driveways. (8.5 ft. above recreational or walking areas, 10 ft. above driveways). Electrical wires may not rub against buildings or roofs. If these conditions are not met mark as **”Repair/replace.”** If the electrical wires are between 8.5 and 10 feet above recreational or walking areas, mark as **”Suggested Correction”** and comment.
- D. Check all GFCI outlets using an electrical outlet-testing device. If any GFCI outlet is improperly installed or ungrounded three prong outlets, mark as **”Below City Requirements.”**

MISC

93. Egress / Ingress Obstruction

Determine if there is an excessive amount of clutter. Accumulations of rubbish, garbage or other materials shall not be stored or allowed to accumulate in stairways, passageways, doors, windows, fire escapes and other means of egress. Mark as **“Repair/Replace”**.

94. Sanitation / Waste

Determine if there is an excessive sanitation problem (e.g. excessive garbage, human or animal waste, or standing sewage, etc). If this is found, mark as **“Repair/Replace.”** (Appendix 4a).

95. Vermin

Determine if there are vermin (cockroaches, mice, rats, insects, etc) in the dwelling. If found, mark as **“Repair/Replace”** and comment: **“Licensed pest control contractor must provide documentation that infestation problem has been abated”** (Appendix 5).

96. Decks / Guards (Walls/Guardrails/Railings)

A. Determine if there is potential for structural failure. If found, mark as **“Repair/Replace.”**

B. Any raised floor surface more than 30” above any floor or grade below shall have guards not less than 36 inches high and any openings must be less than 4 inches. If the guards do not meet these minimums, or are loose, or if nails or fasteners are above the deck surface, mark as **”Suggested Correction.”**

Appendix 1

Minnesota State Plumbing Code

4715.0800 Mechanical Joints

Subpart. 5. Mechanical pipe couplings and fittings. Couplings must be made with the housing fabricated in two or more parts of ductile or malleable iron castings in accordance with Federal Specification QQ-I-666c, Grand 11, or with ASTM A47 or ASTM A339. The coupling gasket must be molded synthetic rubber, per ASTM D-735-61, Grade No. R615BZ. Coupling bolts must be oval neck track head type with hexagonal heavy nuts, per ASTM-A-183-60, or ASTM A325.

Pipe fittings used with these pipe couplings must be fabricated or malleable iron castings in accordance with Federal Specifications QQ-I-666c, Grade 11, or with ASTM A47; ductile iron ASTM A339; segweld steel ASTM53 or A106; or IAPMO-approved copper fittings with rolled grooves intended to be used together with copper tubing with cold rolled grooved ends.

These couplings and fittings may be used above ground, for storm drains and leaders, and for water distribution pipe provided exposed parts in contact with water are galvanized, and may be used below ground for water distribution if couplings and fittings are galvanized and the exposed grooves are coal tar enamel coated and wrapped.

Saddle-type fittings secured by steel electroplated U-bolts may be used for above ground water distribution, if the fittings are galvanized, include a collar fitting into the pipe opening with a gasket, and have IAPMO approval.

Appendix 2

City of Robbinsdale City Code

Section 410.23 – Building addresses (excerpt)

410.23. Building addresses. Structures fronting upon a public or private right-of-way must at all times conspicuously display the address number of the subject premises. If the structure also abuts an alley, building numbers must also be attached in a conspicuous location to the alley side of the structure. If a garage or similar accessory building obstructs the view of the main structure from the alley, the building numbers for the structure must be placed in a conspicuous location on the garage or accessory building. **Address numbers are assigned by the City engineering department.** Address numbers must measure a minimum of four inches in height and may not exceed one foot in height.

Appendix 3

Privacy. Dwelling units, hotel units, rooming units and dormitory units shall be arranged to provide privacy and be separate from other adjoining spaces.

Minimum Room Widths. A habitable room, other than kitchen, shall not be less than 7 feet in any plan dimension.

Minimum Ceiling Heights. Habitable spaces, hallways, corridors, laundry areas, bathrooms, toilet rooms and habitable basement areas shall have a clear ceiling height of not less than 7 feet.

Exceptions:

1. In one- and two-family dwellings, beams or girders spaced not less than 4 feet on center and projecting not more than 6 inches below the required ceiling height.
2. Basement rooms in one- and two-family dwellings occupied exclusively for laundry, study or recreation purposes, having a ceiling height of not less than 6 feet 8 inches, with not less than 6 feet 4 inches of clear height under beams, girders, ducts and similar obstructions.
3. Rooms occupied exclusively for sleeping, study or similar purposes and having a sloped ceiling over all or part of the room, with a clear ceiling height of at least 7 feet over not less than one-third of the required minimum floor area. In calculating the floor area of such rooms, only those portions of the floor area with a clear ceiling height of 5 feet or more shall be included.

Room Area. Every living room shall contain at least 120 square feet and every bedroom shall contain at least 70 square feet.

“The number of persons occupying a dwelling unit shall not create conditions which, in the opinion of the building official, endanger the life, health, safety, or welfare of the occupants.”

Nothing in this section shall prohibit an efficiency living unit from meeting the following requirements:

1. A unit occupied by not more than two occupants shall have a clear floor area of not less than 220 square feet. A unit occupied by three occupants shall have a clear floor area of not less than 320 square feet. These required areas shall be exclusive of the areas required by Items 2 and 3.
2. The unit shall be provided with a kitchen sink, cooking appliance and refrigeration facilities, each having a clear working space of not less than 30 inches in front. Light and ventilation conforming to this code shall be provided.
3. The unit shall be provided with a separate bathroom containing a water closet, lavatory and bathtub or shower.
4. The maximum number of occupants shall be three.

Appendix 4

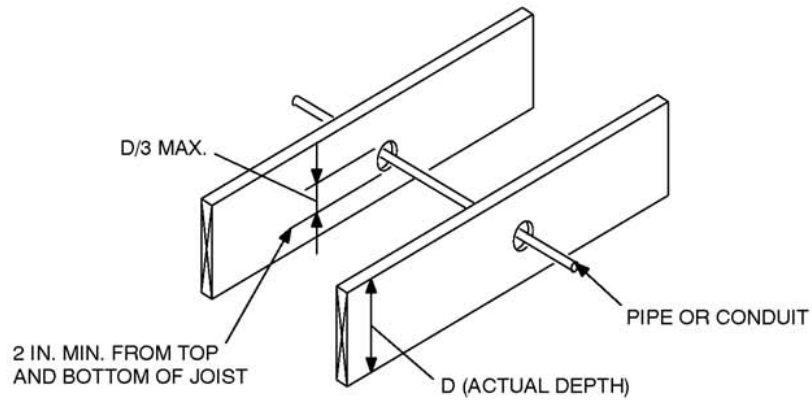
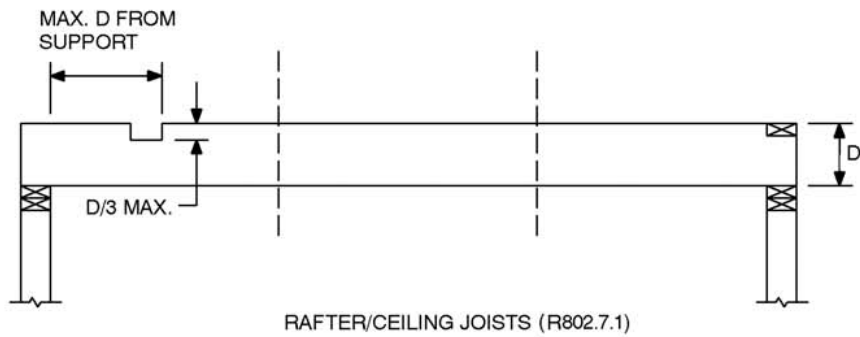
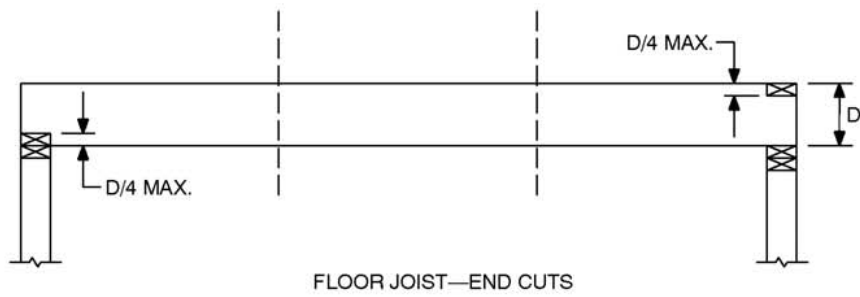
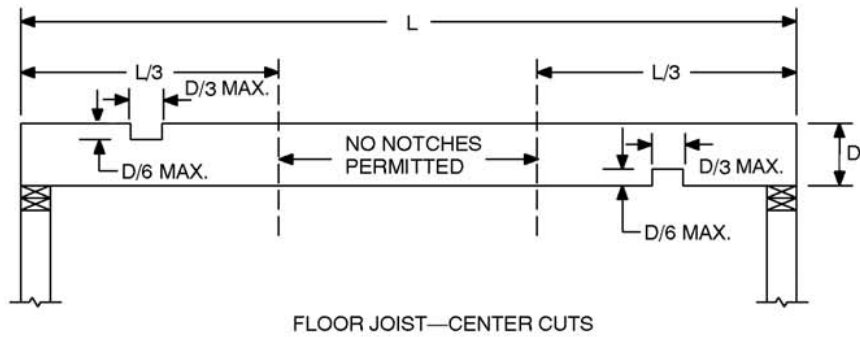

Appendix 5

Infestation. All structures shall be kept free from insect and rodent infestation. All structures in which insects or rodents are found shall be promptly exterminated by approved processes that will not be injurious to human health. After extermination, proper precautions shall be taken to prevent re-infestation.

Owner. The owner of any structure shall be responsible for extermination within the structure prior to renting or leasing the structure.

Single Occupant. The occupant of a one-family dwelling or of a single-tenant nonresidential structure shall be responsible for extermination on the premises.

Multiple Occupancy. The owner of a structure containing two or more dwelling units, a multiple occupancy, a rooming house or a nonresidential structure shall be responsible for extermination in the public or shared areas of the structure and exterior property. If infestation is caused by failure of an occupant to prevent such infestation in the area occupied, the occupant shall be responsible for extermination.

Occupant. The occupant of any structure shall be responsible for the continued rodent and pest-free condition of the structure. **Exception:** Where the infestations are caused by defects in the structure, the owner shall be responsible for extermination.

Appendix 6

Appliance Fuel Connectors

Sec.2214. Appliance connections shall have a diameter not less than that of the inlet connection to the appliance as provided by the manufacturer and each appliance shall be rigidly connected to the gas piping with materials as provided in Section 2212.

EXCEPTION: A gas appliance may be connected with an approved listed metal appliance connector under the following conditions:

1. Listed metal appliance connectors shall have an overall length not to exceed 3 feet, except range and domestic clothes dryer connectors, which may not exceed 6 feet.
2. Connectors shall not be concealed within or extended through wall, floor or partition.
3. A listed appliance connector valve not less than the nominal size of the connector shall be accessible at the gas-piping outlet immediately ahead of the connector.
4. Connectors shall be of adequate size to provide the total demand of the connected appliance based on Table No. 22-B-1 or 22-B-2 as applicable.
5. Aluminum alloy connectors may be used only in interior locations where they shall not be in contact with masonry, plaster or insulation or are not subject to repeated corrosive wettings.
6. The connection of an indoor appliance with any type of gas hose is prohibited, except when used for laboratory or shop equipment that requires mobility during operation. Such connections shall have the shutoff or stopcock installed at the connection to the building piping. When gas hose is used, it shall be of the minimum practical length, but not to exceed 6 feet, except for hand torches and special mobile equipment, and shall not extend from one room to another nor pass through walls, partitions, ceilings or floors. Gas hose shall not be concealed from view or used in a concealed location. Only listed gas hose shall be used in accordance with its listing. Gas hose shall not be used where it is likely to be subject to temperatures exceeding 125°F., nor shall it be used as a substitute for a standard appliance connector.
7. Outdoor portable appliances may be connected with an approved outdoor hose connector not to exceed 15 feet in length, provided it connects outdoors to approved gas piping including an approved valve at the inlet of the hose connector.
8. Appliances may be connected to fuel-gas piping with an approved listed quick-disconnect device.

Point of Sale



City of Robbinsdale

Application For Certified Evaluator

4100 Lakeview Ave N, Robbinsdale, MN. 55422, 763-531-1269

www.robbinsdalemn.com

To obtain a Robbinsdale Certified Evaluator Certificate, please complete the sections below:

| Section I – Applicant Data | | | |
|---|------------------|-----------------|------|
| Name of Evaluator: | Email Address: | | |
| Address: | City: | State: | ZIP: |
| Telephone Number: | Fax Number: | | |
| Section II – Evaluator Proof of Competency | | | |
| Please attach a copy of your Truth-In-Housing Certificate or ID Card from the City of Minneapolis, City of St. Paul, or City of Bloomington. <input type="checkbox"/> City of Minneapolis Competency Certificate <input type="checkbox"/> City of St. Paul competency Certificate <input type="checkbox"/> City of Bloomington competency Certificate | Name of Holder: | | |
| | Number: | | |
| | Expiration Date: | | |
| Section II – Proof of Insurance | | | |
| Please provide proof of the following: <ol style="list-style-type: none"> 1. Proof of Workers' Compensation Insurance if applicable. 2. Proof of General Liability Insurance meeting city requirements: <ul style="list-style-type: none"> • Minimum limit of liability of \$250,000. 3. Proof that the City of Robbinsdale is named as an insured on the above insurance policies and that the insurance is maintained continuously in force. | | | |
| Application Fee | | | |
| <input type="checkbox"/> \$50.00 Initial certification, \$25.00 annual renewal (please make checks payable to the City of Robbinsdale) | | | |
| <i>I hereby certify that I have read and examlned this application and know the same to be true and correct.</i> | | | |
| Signature of Applicant | | Date: | |
| OFFICE USE ONLY | | | |
| Date Received: | Received by: | Receipt Number: | |